

Ventilated Façades: Cost efficient contribution
to lower energy consumption
and CO₂ emissions



Up North

Nuuk, Greenland

Latitude 64° 10' 48" N Longitude 51° 43' 12" W

Average yearly temperature -0.6° C

SWISSPEARL®

PREMIUM

SWISS QUALITY

FAÇADE SYSTEMS

FOR HIGH-END

ARCHITECTURE



Challenges to face - Urgently

- 3 Climate change

Planet Earth

- 4 Earth systems, human systems
- 5 Changing temperatures, impacts
- 6 Extreme events
- 7 Causes of observed changes
- 8 Energy consumption and CO₂ issues
- 9 Limited production capacities

Possible paths for a better future

- 10 Economic mitigation potentials

Ventilated rain-screen cladding

- 11 Building design
- 12 Efficient building technology
- 13 Energy efficiency
- 16 Energy cost saving

SWISSPEARL Ventilated façades

- 18 Life cycle costs
- 19 Perforated panels
- 20 Benefits

Rising temperatures with melting ice sheet and glaciers, increasing number of extreme events such as cyclones, storms and floods, extension of deserts whilst huge forests or whole ecosystems disappear, always more endangered species ...



View of the Trift Bridge and the Trift Glacier, Switzerland

Today, the relationship between the changes observed over the last few decades and human activities with the build-up of CO₂ is quite certain. Industry, transport and buildings are the main responsible for this evolution. Fossil-based energy is also sure to be the greatest contributor of greenhouse gas emissions, whereas the era of cheap energy seems definitely to be over because supply capacities do no longer meet the continuously growing energy demand.

According to official EU data, buildings use more than one third of the worldwide energy consumption, namely for constructing, operating, renovating to provide the living and working space with the desired day-to-day comfort. Simultaneously, the corresponding costs and the saving potential are huge over a life span of 40 - 50 years. Traditional design, construction and retrofit methods must be adapted. This means that architects and investors have a major responsibility towards society and future generations.

Climate change and greenhouse gases are pressing issues that cannot be ignored any longer, even though scientists still need to work on various uncertainties lacking sufficient verified knowledge and consensus.

Many energy-efficient solutions exist already today for many fields of application; architects need to explore and incorporate the green and efficient solutions into their building concepts. Building envelopes featuring the latest low-energy technology are one environmental, cost-cutting path. For instance, the ventilated façade systems, so far mostly used in European countries with long and severe winters, have proven their cost- and energy-efficiency for over 30 years both in new and refurbishment projects. Built according to the state-of-the-art with high thermal insulation and high quality, durable skin materials, ventilated façade systems tremendously reduce the energy bill for heating and cooling services and the CO₂ emissions of the building, at the same time providing comfortable and cosy indoor conditions. They keep a building structurally sound and effective over many and many years without heavy maintenance. The worlds of architecture and construction have exciting challenges ahead. For our planet's sake, let inspired architects continue to bring creative beauty, attractive living or working space with green performance in our life.



The protection of the climate and the environment requires from everybody contributions to minimize the detrimental effects of the industries and societies turned to always higher consumption!

IPCC
Climate Change 2007;
Fourth Assessment
Report

Urgent action is needed due to high inertia in human, economic and natural systems. Societies can adapt their habits and behaviour to mitigate the impacts of human activities on the climate.

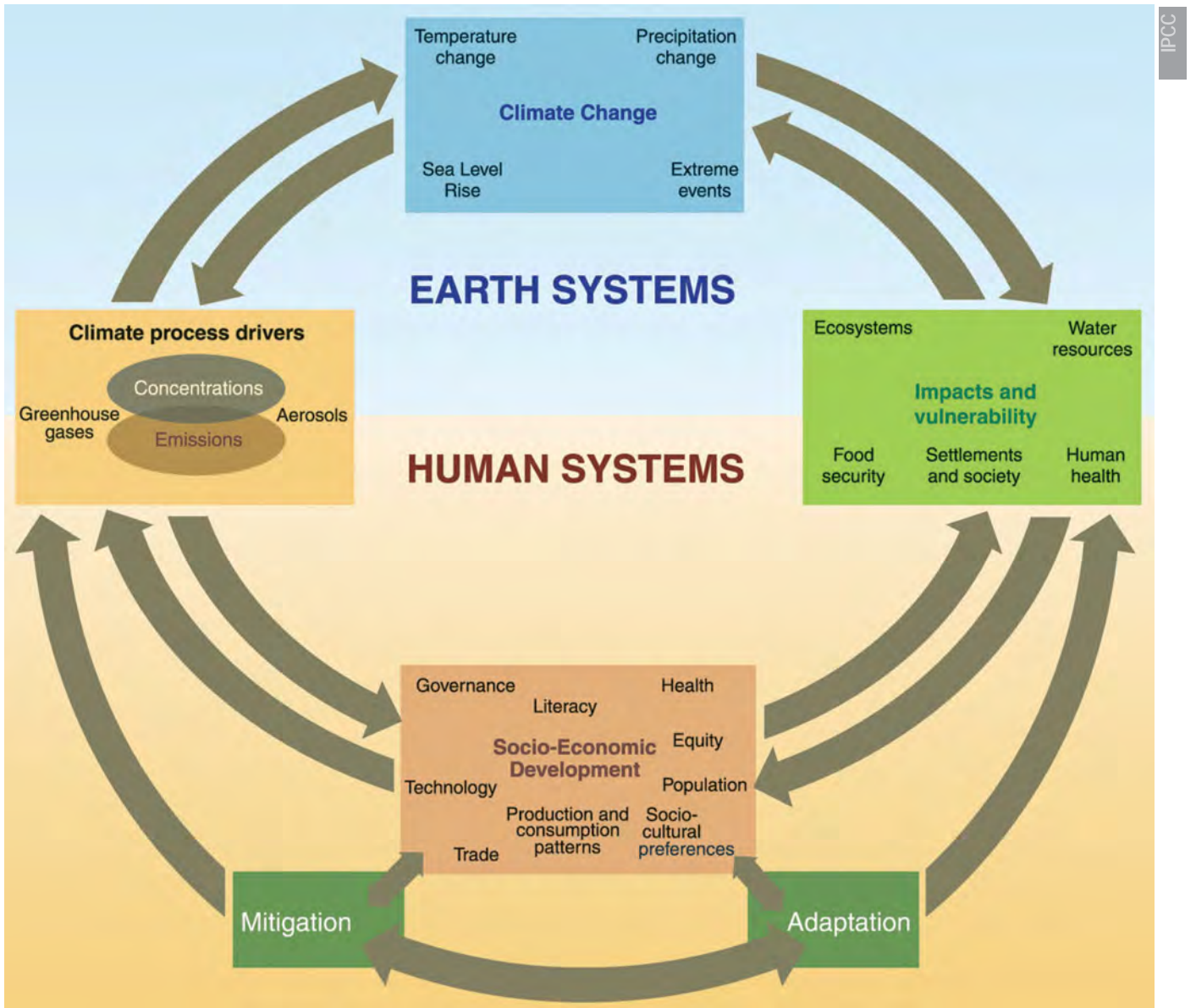

IPCC

Schematic framework of anthropogenic climate change drivers, impacts and responses

NCDC/NESDIS/
NOAA
Surface temperature change

Since the earth has existed, natural climatic variations periodically occurred but took place over very long periods, such as the glacial and interglacial cycles. Unusual in the recent climate development is the speed at which the changes have taken place within 150 years and the dramatic acceleration in the past 50 years.

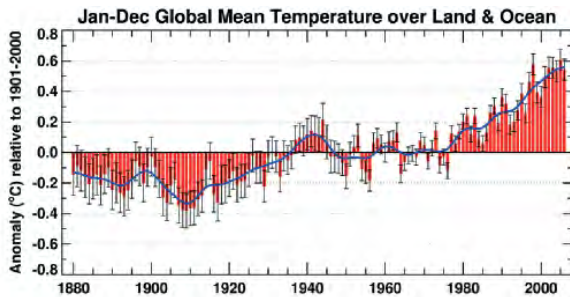

Annual Average Global Surface Temperature Anomalies 1880-2006. Courtesy NOAA (Surface temperature records have been quality controlled to remove the effects of urbanization at observing stations in and around cities).

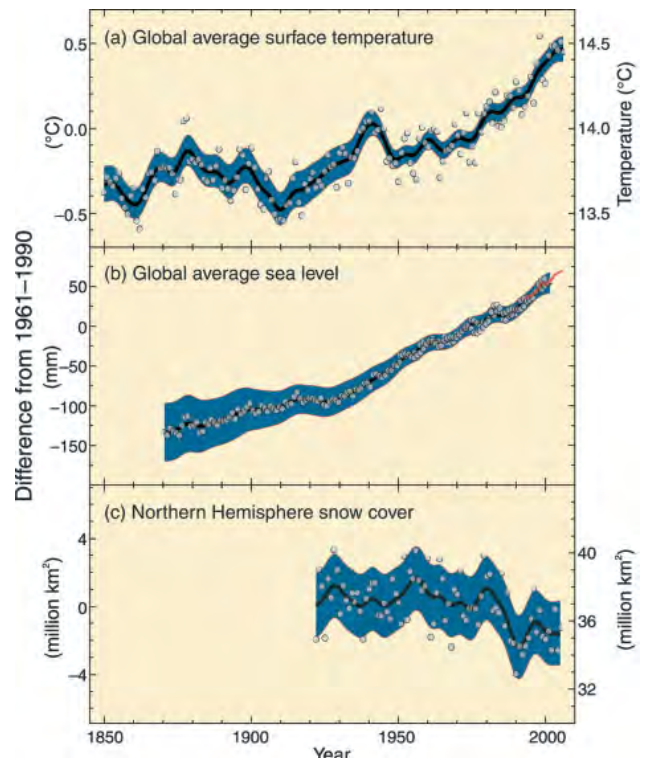

Changes in temperature, sea level and Northern Hemisphere snow cover

Surface temperature of the earth

Since the mid seventies, weather stations all over the world have reported rising temperatures

- Within 50 years, the average surface temperature has increased by approximately 0.65 °C (1.2 °F)
- Current warming rate is about 1.3 °C per century (4.3 °F). The change affects both the minimum and the maximum temperatures

- The eleven recent years (1995-2006) rank among the 12 warmest years in the instrumental record since 1850
- At the poles, the increase in average temperature is nearly twice the global rate
- Land areas warm up faster than the oceans, much fewer freezing days in particular in the Northern hemisphere

Most scenarios project a further temperature increase of approx. 0.4 °C for the next two decades, even if the causes would be kept at the level of year 2000.

Extreme events

There is a high scientific confidence that the observed changes in surface temperature of earth and sea have huge impacts on the terrestrial and marine, natural and biological systems.

M-RE
München Re Group,
Topics Geo Natural
Catastrophes 2007

Most of these effects are insidious and noticed only by specialists. Others, such as the changes in weather, can be experienced by anybody in everyday life or when watching TV ...

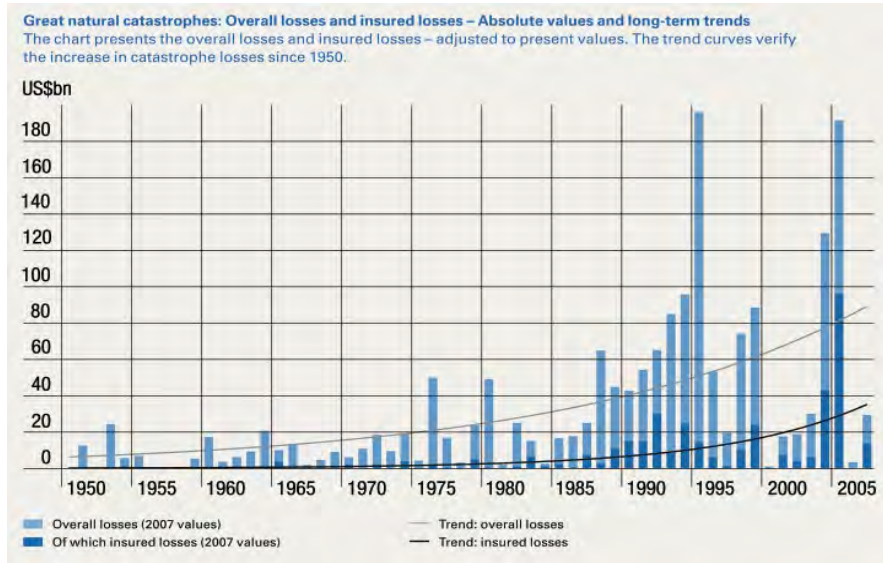

M-RE

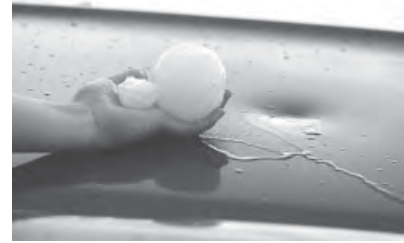

Hail



Flood



Tornado



Storms, wind patterns, etc.

Although regional variability is considerable, it seems that in the Northern hemisphere the frequency and intensity of major weather events have increased, causing huge economic damage and human losses. Such major weather events range from the known tropical or continental storms (for instance Lothar, Katrina, Andrew, Fay, Gustav, Ike, etc.) over unusual tornados or severe hailstorms to heavy thunderstorms and rainfalls with flood catastrophes (in coastal areas and continental interiors)

These extreme events are not predictable and have disastrous economical and societal impacts, partly because insurance companies tend to cover a decreasing share of the sustained losses. These climate impacts are inequally distributed over the globe.

Unusual precipitation patterns

Whereas countries in temperate latitudes experience higher rainfalls, annual average precipitations decrease in the Mediterranean region, northern parts of Africa, Central America and Southwest USA. This aggravates the consequences of the usual dry or drought periods.

Snow and ice

Observations evidence that natural systems related to ice and snow are affected. For instance, the annual average Artic sea ice is shrinking while mountain glaciers and snow cover are declining in both hemispheres.

Incidence of extreme high sea level

The various measurements show that the level of the sea has risen approximately 120 - 220 mm (4.8 - 8.8") in a century with a faster growth rate in recent years. Whereas average rate was 1.8 mm per year from 1961 to 2003, it was about 3.1 mm per year from 1993 to 2003.

This leads to catastrophes in coastal areas when the rising sea level is coupled with other extreme events such as cyclones, storms, etc.



Tornado

Causes of observed changes

According to historical records, important variability in climate is nothing new. Different and alarming are the significant changes noticed within less than 50 years.

Therefore, human activities in the industrial era have influenced the previous balance of the climate system.

Today, there is much evidence and high agreement among scientists and governments that the emission of greenhouse gases are the main drivers of the climate change.

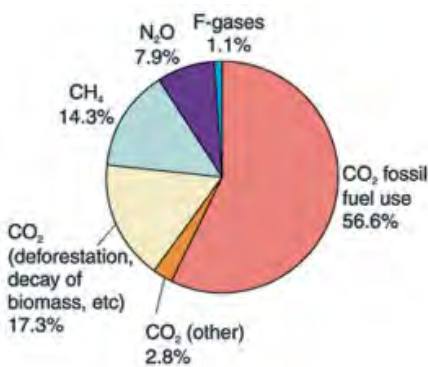

Global anthropogenic GHG emissions

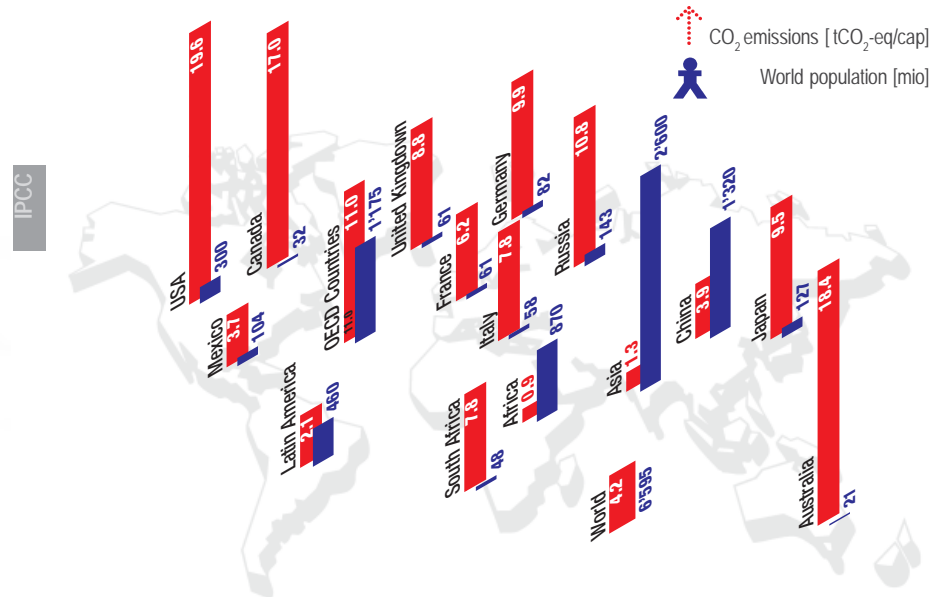

CO₂ emissions per capita and world population 2006

Composition of atmosphere

The concentration in long-lived greenhouse gases (CO₂, methane, nitrous oxide, ozone, aerosols) has greatly increased in the past 2 centuries, and this with an accelerated speed over the past 50 years. Global greenhouse gas emissions due to human activities have increased by 70% since 1970. The main gas with dangerous interferences with the climate system is CO₂ due to fossil fuel use with a share of nearly 60% in these gas emissions.

So far, there is a close link between the level of industrialisation and the regional distribution of the atmospheric concentration of these gases by population and GDP. The industrial nations that are parties to the Annex I Convention of the Kyoto Protocol account for about 20% of the world population. With an average emission level of 16.1 t CO₂-eq/cap, their yearly emissions correspond to nearly 50% of the total. The CO₂ emissions of the remaining 80% of the population reach 4.2 t CO₂-eq/cap.

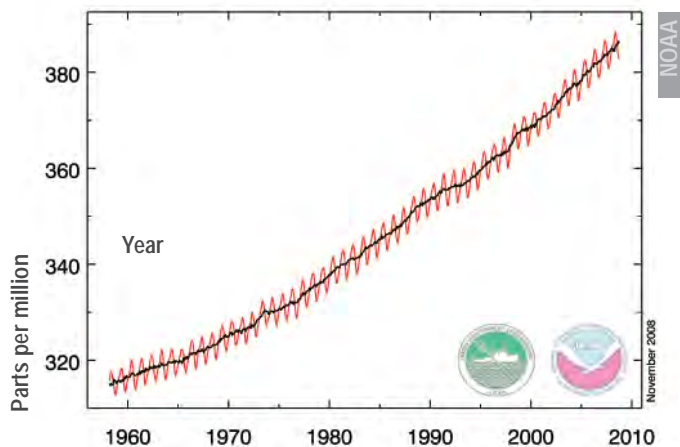

Atmospheric CO₂ at Mauna Loa Observatory

IPCC
Climate Change
2007;
Fourth Assessment
Report
NOAA
Earth System
Research
Laboratory
Scripps institution
of oceanography

Energy consumption and CO₂ issues

- 40.0 % Buildings
- 27.0 % Industry
- 33.0 % Transport

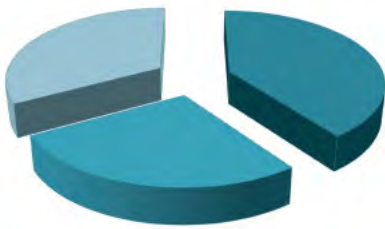

Energy consumption worldwide

For a long time, scepticism and uncertainty have prevailed in the scientific debate.

Meanwhile there is a broad consensus that human activity is very likely the main cause for the worldwide change in climate and the increase in CO₂ levels due to consumption of fossil fuels has been identified as the largest contributor to the warming.

EU27

EU27

European Energy and Transport - Trends to 2030 Update 2007

Present situation

In Europe, each person uses 52'200 kWh. In the USA the energy consumption reaches 104'400 kWh/capita whereas the emerging countries manage with less than 8'800 kWh.

Approx. 65 % of the greenhouse gas emissions are generated by the use of fossil fuel energy.

Presently 35 % of the worldwide CO₂ emis-

sions result from the building sector. In the European Union, some 40 % of energy consumption is necessary for constructing, operating (heating, cooling, lighting, servicing all electrical installations) and maintaining the buildings. Needless to say, designing energy-smart new buildings and upgrading the buildings of the 1980s and before to the present standards correspond to a huge energy saving potential.

Transport and Industry are responsible for the two other thirds of the global CO₂ emissions.

Outlook 2030

The different baseline scenarios set up by the EU, the IEA, the WEC, etc. all come to the conclusion that the worldwide energy demand will continue to increase if various energy efficiency and CO₂ policies are not rapidly implemented:

Total energy requirements will continue to climb due to global population growth, higher economic activities, increased standard of living and higher demand in emerging economies (mainly driven by China and India).

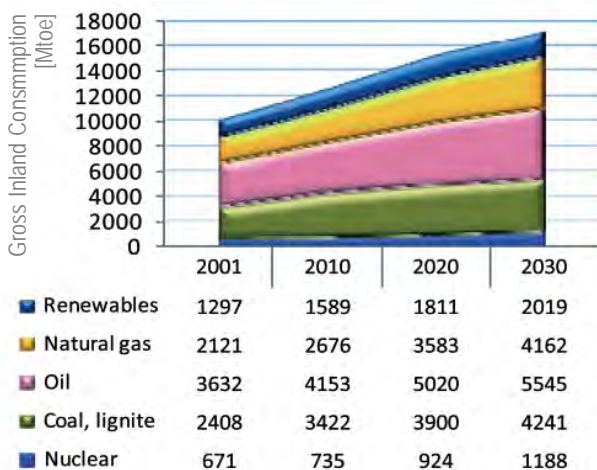

Global energy mix and CO₂ emissions

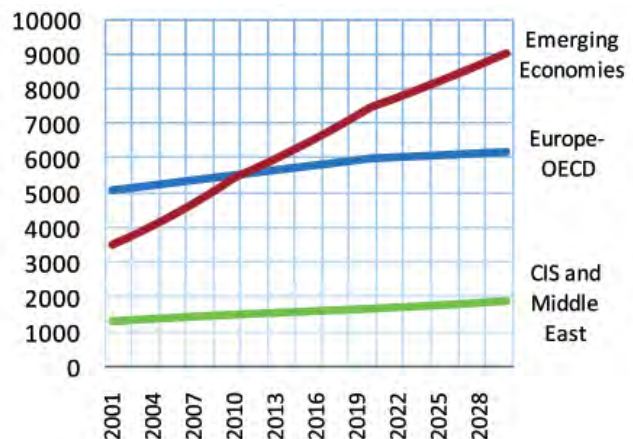

Primary energy consumption [Mtoe]

Limited production capacities

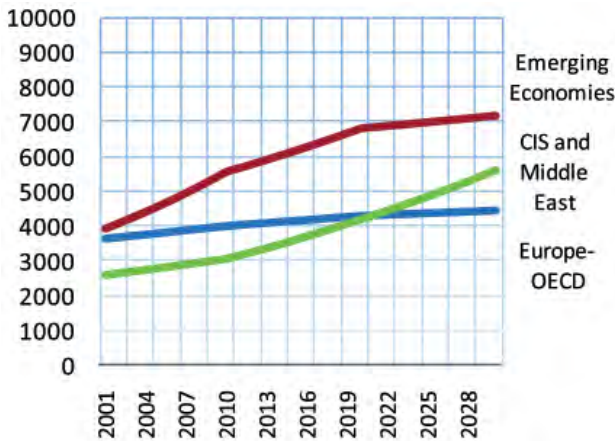

Primary energy Production

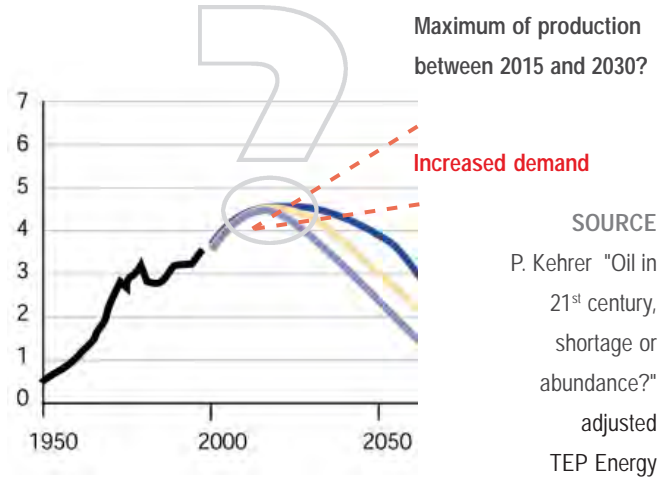

(Possible scenarios in Mia ton/a)

Great uncertainties about future oil capacities

SOURCE
P. Kehrer "Oil in 21st century, shortage or abundance?"
adjusted
TEP Energy

While global energy consumption is projected to grow by about 50% in the next two decades in a business as usual scenario, the share of fossil fuels in total energy supply will remain constant. However, fossil fuels will continue to dominate the energy demand until 2030. Meanwhile the debate about the possible oil-peak and its projected date focuses not only on the declining or newfound resources, but also on the other current bottlenecks in the supply chain. Whereas technology progress may allow a higher extraction efficiency of known reserves or profitable operation of new resources, capacities to extract, transform and transport the fuels are to adapt to allow higher outputs at the necessary rate. Such technology measures require heavy investments and long realisation time. Finally, the increasing concentration on the OPEC countries and in particular on the oilfields in the Middle East, involve risks of supply interruptions and short term price fluctuations due to geopolitical factors.

After a fairly long period of rather stable level, the consumer energy prices went up at a factor of 2.5 within three years.

Due to the gap between demand and supply and to the expensive investments for fossil fuels, electricity supply or alternative energies, future energy prices are not likely to ease down durably, and risks of important fluctuations will remain high. In addition, in various industrial countries, for instance in the European Union, new policies and taxes on energy implemented to reduce the CO₂ output will increase additionally the costs of energy or CO₂ emissions.

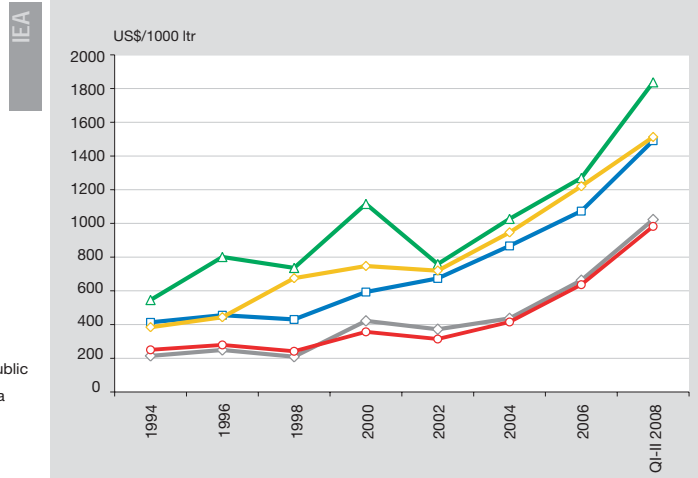

(Nominal prices using PPP to convert into US\$)

Heating oil household end-use energy prices

IEA (2008)
Energy prices and taxes - quarterly statistics - Third quarter 2008.
Paris. ISSN 0256-2332.

For a better future

Since fossil fuel is the main CO₂ contributor, the challenge and the ambitious goal are obviously to curtail (and substitute) tremendously the energy consumption and thus its future influence on the environment.

IPCC
Climate
Change 2007;
Fourth Assessment
Report

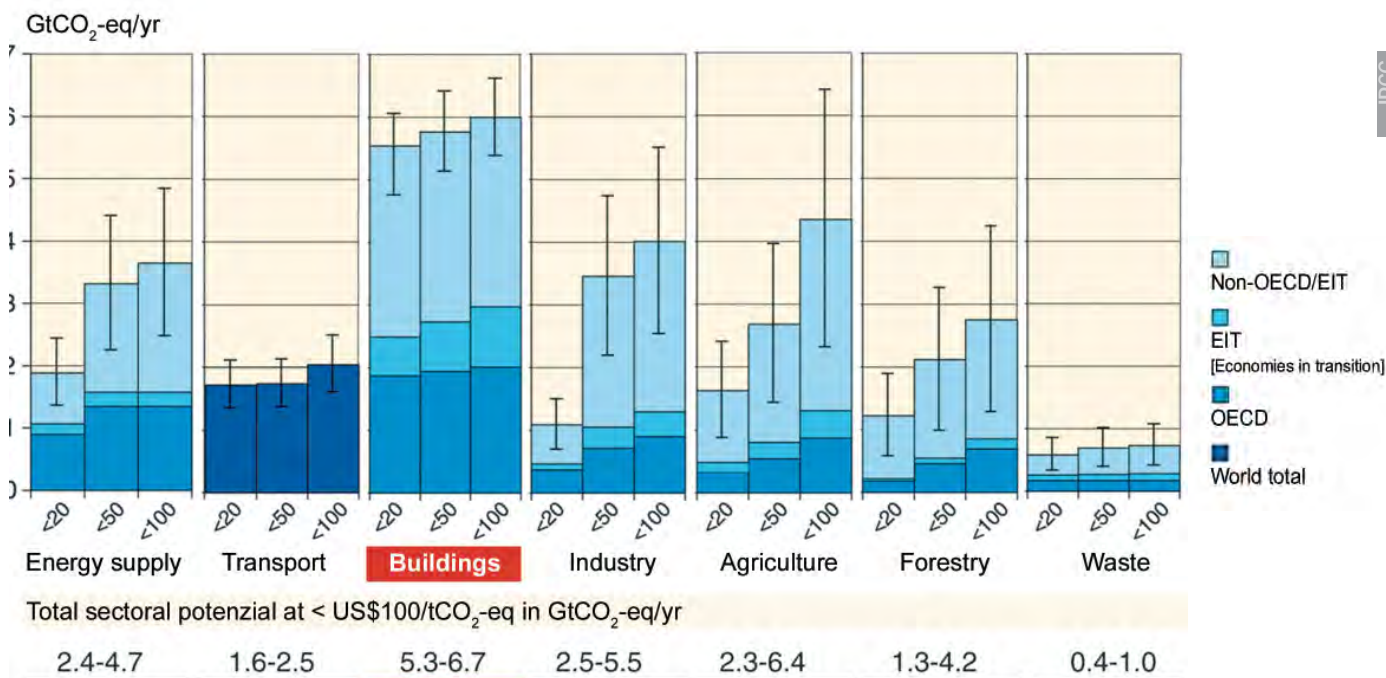

Economic mitigation potentials by sector in 2030 estimated from bottom-up studies [GtCO₂-eq/yr]

According to the IPCC assessment, all sectors have a large mitigation potential; however, buildings, industry and agriculture offer the highest possibilities.

Buildings, generally speaking, offer the largest and most cost-effective opportunities to boost energy productivity. Various studies such as those from McKinsey (2008), Ecofys, ACEEE, ECEEE, IEA, etc., show that in this sector, measures to improve energy efficiency stand out as the most profitable way to curb demand and emissions growth. Actually, most of the avoidance pathways with negative costs, thus economic benefits, could be implemented in existing and new buildings, including technologies and appliances.

The building sector already has today the best opportunities to reduce the CO₂ emissions since mitigation measures are either profitable or can be achieved with costs below 20 US \$/tCO₂-eq.

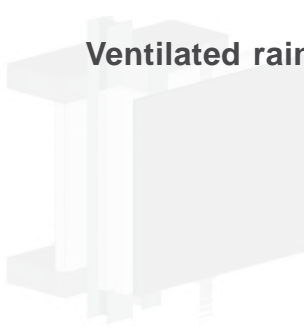

Building design

There are many fields in which the energy needs in a building may be curbed, although energy demand is sure to grow because users want an ever higher level of comfort.

This leads, for instance, to higher cooling needs in industrial countries, not only because of rising average temperatures. One of the most efficient ways to reduce the impact on the environment, both in cold and in warm climates, is the building design.

In addition to spatial layout, volume and orientation of the building, the appropriate position, dimensioning, material and technology choice and combination of buildings elements such as windows, façade, solar protection are of great importance.



Sidney, Australia



Monterrey, Mexico



Palanga, Lithuania

Energy friendly design starts with the appropriate orientation of the building, the spatial layout, the appropriate size and position and the optimal material for buildings elements such as windows, heating or shading systems, mechanical appliances, etc.

- Building envelopes with
 - high thermal insulation
 - windows in appropriate size and technology in hot and cold countries, etc.
 - inclined façades, a sufficient share of opaque walls on the sun exposed sides (light being provided by other means such as perforated elements, pit systems for natural light, etc.)require much less heating, cooling or lighting energy. The right commissioning of the electric systems also contribute to lowering energy consumption. Estimations say that energy conservation measures, for instance through insulating systems, are necessary for at least 75 % of the existing buildings in the industrial countries.

Façades walls influence approximately 20 % of the energy requirements of buildings and thus offer enormous possibilities for substantial improvement.

■ Today insulation standards stipulated by building codes vary a lot from country to country. The range spreads from zero in East Europe and Overseas to 200 mm thickness and more in some European countries. The low-energy or passive-energy building currently in trend in Switzerland, Germany, etc. evidence how effective climate friendly concepts can be.

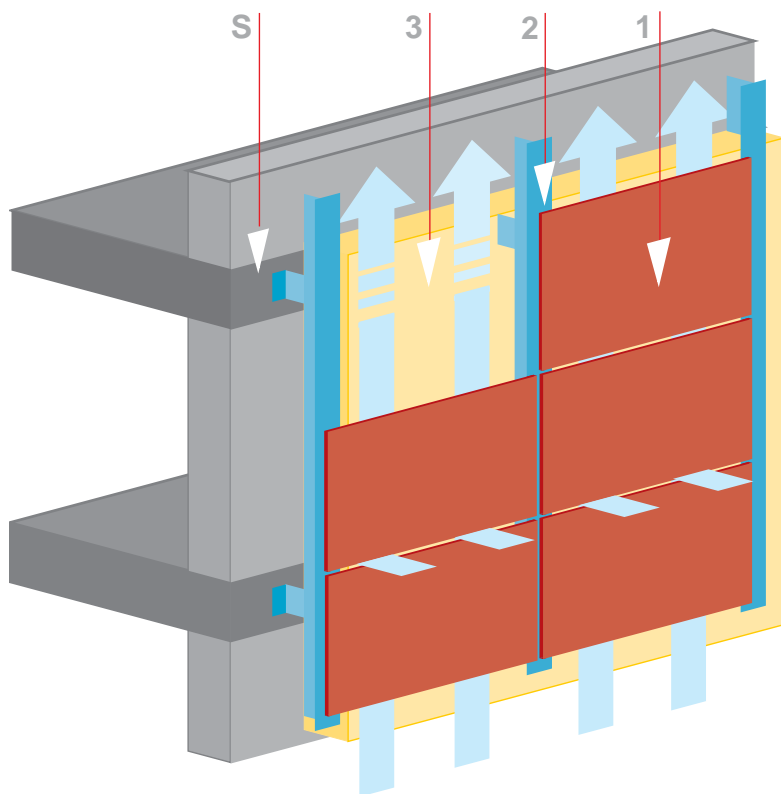

Multi-layered structures by functional separation

S **Support structure**

Type of construction and used materials vary with the local building codes and practices of the countries. They provide a basic energy performance of the building, which depends on the wall construction, but is in most cases far too low to reduce significantly the energy bill.

1 **Cladding**

The main functions of the outer cladding are both aesthetic and protective. It deflects the majority of rainfall and protects the insulation against climatic stresses and mechanical impact.

The cladding panels, statically independent of each other, are anchored to the exterior wall by a light and stable sub-structure.

Swisspearl cement composite panels are ecologically sound products with a low embodied energy and a life expectancy of at least 40 years. They are guaranteed from -40 °C up to +80 °C. In addition, the inert material does not lead to significant heat build-up, so that in sun exposition and/or hot climates the difference between air temperature and surface temperature is max. 10-15 °C.

This feature has a beneficial effect on cooling needs.

Ventilated type façades consist of multi-layered structures characterized by a distinct functional separation of the individual component layers.

2 **Air cavity**

The lack of ventilation associated with humidity causes condensation and rotting of construction materials. These are ideal conditions for the development of mould and bacteria with their adverse effects on the durability of the building structure, as well as on health and living comfort. Furthermore, humidity on insulation reduces significantly its effectiveness and thus the potential energy savings. All these issues do not exist with the ventilated façade system. Air circulation happens naturally thanks to the difference in pressure between the bottom and the top of the façade. The air gap drains off atmospheric and internal humidity, as well as any moisture present in the masonry; on the other hand, it regulates the thermal exchange between the building and the environment in terms of natural ventilation. In higher temperatures, the circulating air evacuates part of the heat.

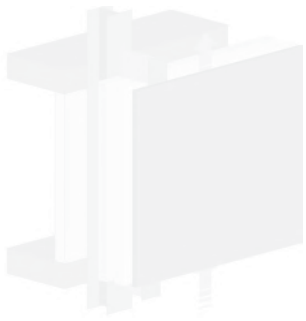

Ventilated façades built according to the state of the art with the thickness of thermal insulation appropriate for the local conditions have proven their efficiency over a long period in many European countries.

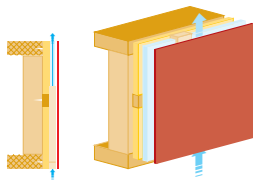
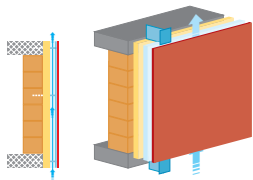
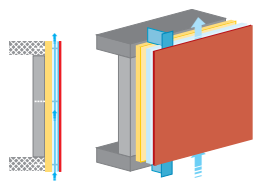
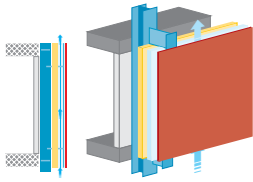

Example CMU/Concrete

No insulation

U-Value = 3.581 W/m² K

R-Value = 0.282 m² K/W

Additional insulation 30 mm

U₁-Value = 0.896 W/m² K

R₁-Value = 1.118 m² K/W

Improvement

$\Delta U_1 = 2.685 \text{ W/m}^2 \text{ K} \sim 75 \%$

Additional insulation 50 mm

U₂-Value = 0.597 W/m² K

R₂-Value = 1.673 m² K/W

Improvement

$\Delta U_2 = 2.984 \text{ W/m}^2 \text{ K} \sim 83 \%$

The larger the R-Value is, the better is the building insulation's effectiveness.

The lower the U-Value of a wall, the less the heating energy loss, and the higher the inside surface temperature of the envelope construction.

3 Insulation

As a principle, insulation slows down the flow out of the buildings of conditioned heat and coolness. Insulation retains the heat of the room in the wall structure for solid walls and eliminates thermal bridges.

Energy efficiency of insulation depends on the Lambda-value of the used material, but above all on the thickness of the insulation layer, which together determine the thermal resistance value R [m²K/W]. The R-Value is the reciprocal of the U-factor, which measures the heat transfer across the wall element (W per m² and per Kelvin of temperature difference between indoor and outdoor). Requirements and optimal thermal insulation depend on regional climate and local environmental factors.

- Steelstud frame
- CMU/Concrete plastered
- ▲ Masonry plastered
- ◆ Wooden wallboard/studding

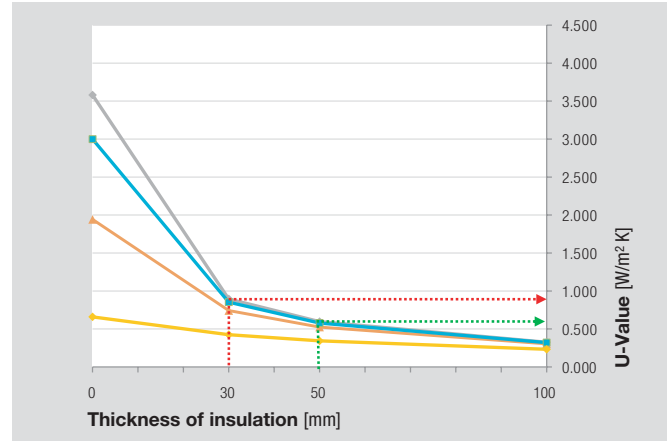

Reduction of U-Value of wall

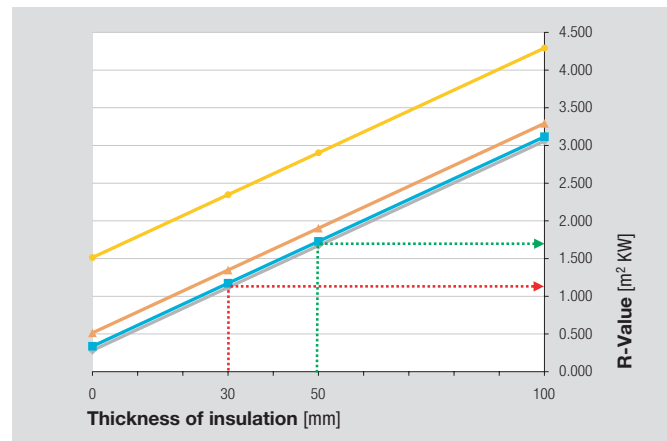

Increase of R-value of wall

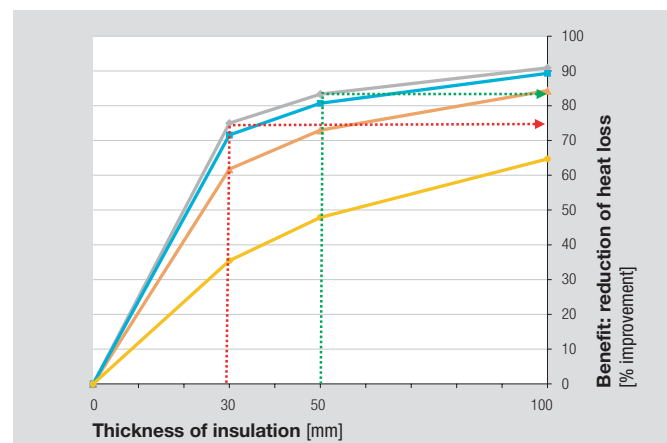

Reduction of heat loss

Energy efficiency

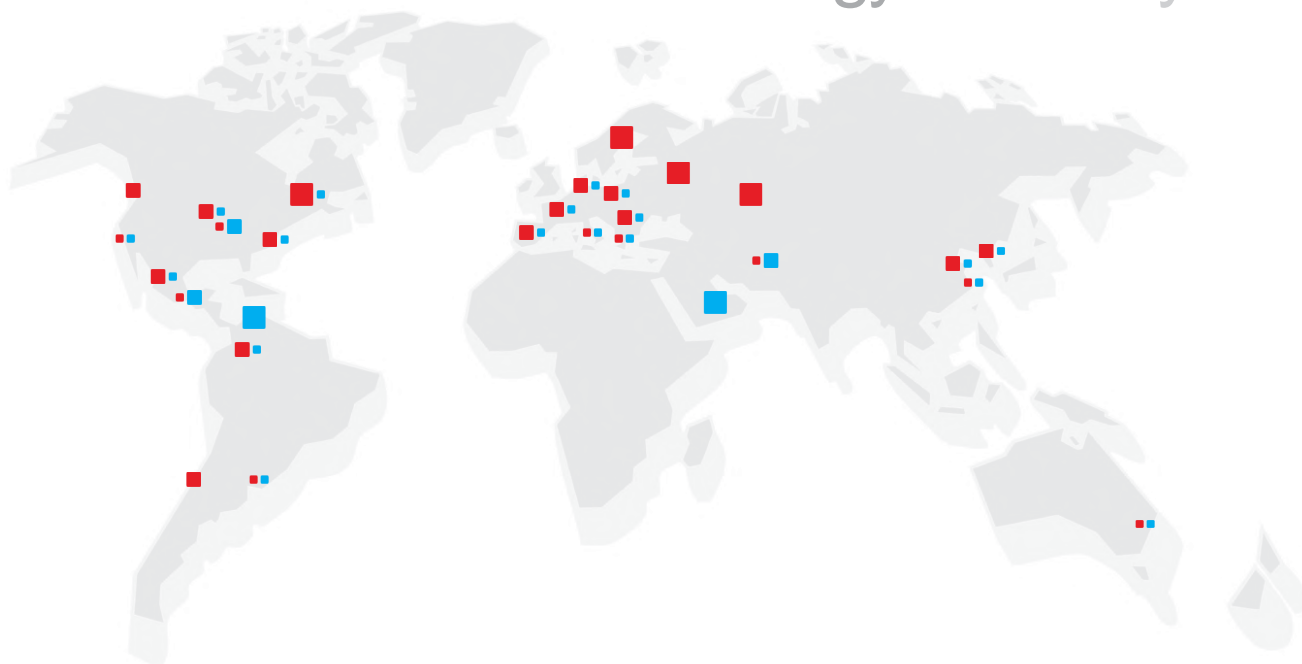

Country	Location	HDD *	CDD *	
		Heating degree days	Cooling degree days	
		Average 06/07	Average 06/07	
Europe	Bulgaria	Sofia	3046	519
	France	Paris	2484	285
	Germany	Berlin	3010	324
	Greece	Athens	1480	1033
	Italy	Rome	1622	839
	Poland	Warsaw	3562	302
	Russia	Moscow	4781	210
	Spain	Madrid	2134	775
	Sweden	Stockholm	4100	152
Other	USA	Burbank	984	1129
		Chicago	3273	688
		Dallas	1116	1905
		Washington	2100	1048
	Canada	Montréal	4185	372
		Vancouver	2934	110
	Mexico	Mexico City	1020	572
		Monterrey	443	2599
	Chile	Santiago	1768	62
	Columbia	Bogotá	1835	586
	Venezuela	Caracas	1	3561
	Argentina	Buenos Aires	1024	834
	UA Emirates	Abu Dhabi	106	3808
	Pakistan	Islamabad	674	2295
	Russia	Ekaterinburg	5867	194
	China	Shanghai	1431	1438
Beijing		2769	1046	
South Korea	Seoul	2889	774	
Australia	Sidney	729	882	

* Degree days are widely used for calculations relating to the effect of outside air temperature on building energy consumption. Heating degree days (HDD) and cooling degree days (CDD) are used to characterize the heating and the cooling season respectively. HDD and CDD are defined as the sum of the differences between the daily mean temperatures and the balance temperature (18°C) of those days with a daily mean temperature below (HDD) or above (CDD) a certain threshold temperature (in this brochure 18°C for both HDD and CDD).



Building before and after renovation with SWISSPEARL ventilated façade system

Milan, Italy

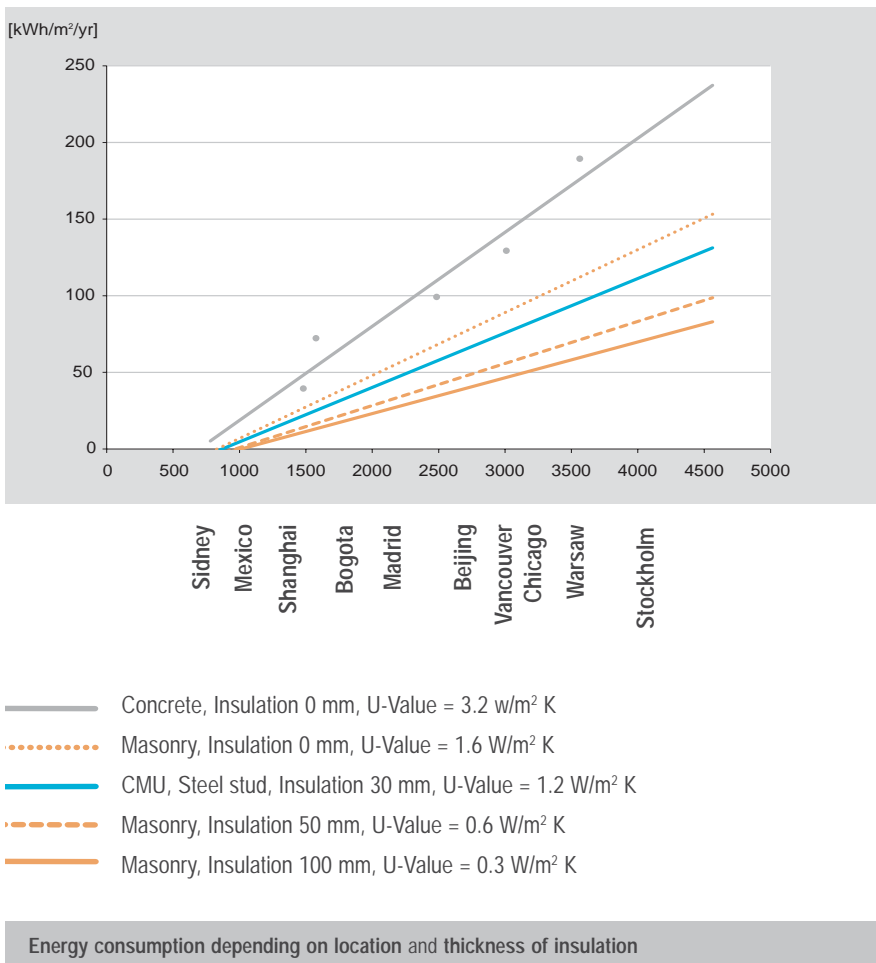

The impact of different insulation levels on the heating energy demand of buildings was estimated for the case of a typical office building for several locations with different HDD. The ratio of wall area to heated floor was assumed at 0.66. Clearly, buildings with non-insulated façades exhibit a much higher energy demand per m² of heated floor area (see graph). From an economic, energy price risk and indoor comfort point of view, it is recommended to insulate ventilated façades with 100 to 200 mm in the case of locations with HDD above 3000, between 80 to 120 mm for locations with HDD between 2000 and 3000, and between 50 and 100 mm for all other locations.

Ventilated façades with insulation also contribute to a reduction of the cooling energy consumption in regions that require much cooling (> 2000 CDD).

Note that the benefit considerably depends on the way building is designed and operated (external and internal heat loads).

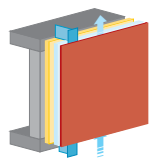
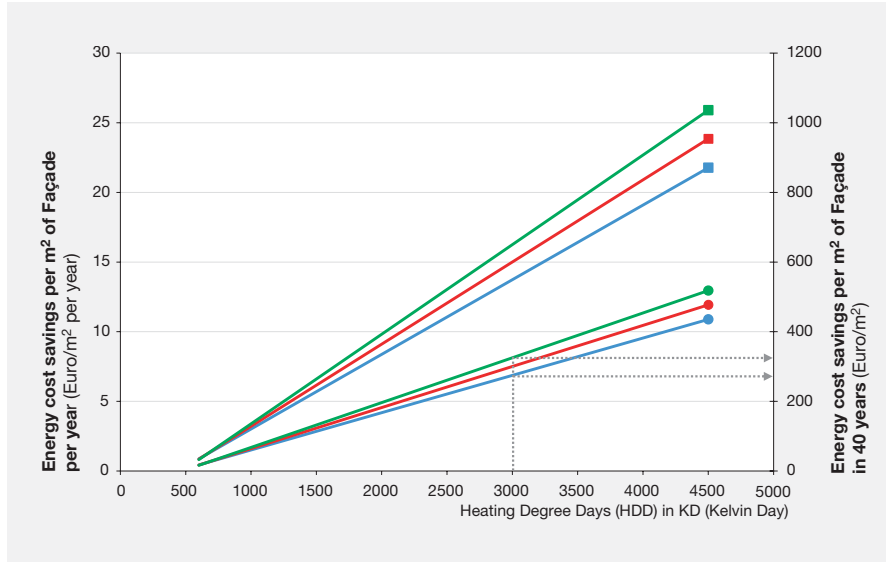

Sydney
Mexico
Shanghai
Bogota
Madrid
Beijing
Vancouver
Chicago
Warsaw
Stockholm

Concrete Wall

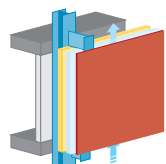
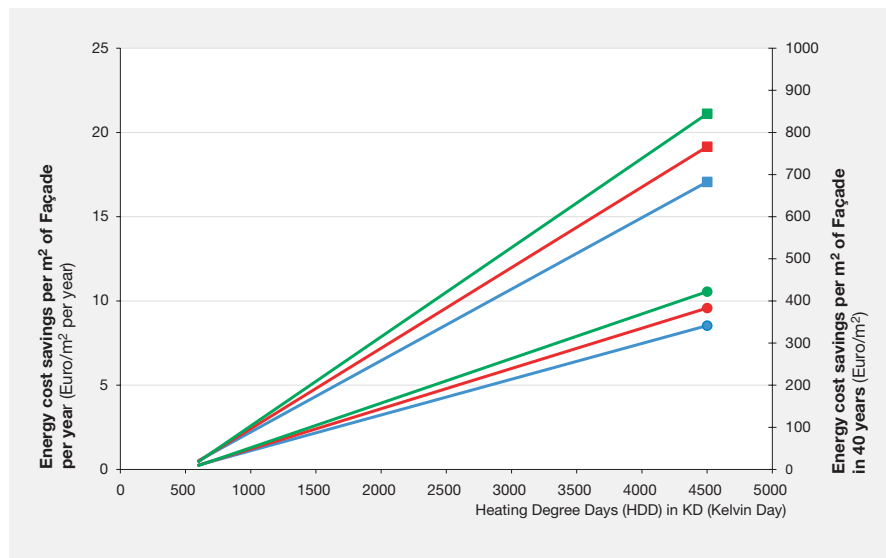

Sydney
Mexico
Shanghai
Bogota
Madrid
Beijing
Vancouver
Chicago
Warsaw
Stockholm

Steel studs

For a location with a HDD value of ~ 3000 KD such as Berlin (Germany) or Vancouver (Canada), energy cost savings thanks to insulation of 30 mm to 100 mm of a concrete wall amount to about 7-8 Euros per square metre each year. This corresponds to ~ 280 Euro/m² to 320 Euro/m² for a life span of 40 years if future energy prices are assumed to be low (0.05 Euro/kWh or 50 Euro/100 litre of heating oil).

However, if an energy price of about 0.1 Euro/kWh is assumed to be more realistic, energy cost savings are doubling to about 14-16 Euros per square metre façade per year or 550 to 650 Euro/m² in fourthy years. In colder regions with higher HDD values such as Canada or the north of Europe and the USA, energy cost savings are even higher (see graph).

Even in regions and cities with more moderate climate such as Rome, Spain, Bogotá, Seoul or Beijing, energy cost savings due to wall insulations are notable. Also in locations with HDD values of about 2000 KD, energy cost savings allow for pay-ing down the façade investment costs by about 150-200 Euros per square metre.

- €/kWh
- P1 0.05
 - P2 0.10

- Insulation
- 30 mm
 - 50 mm
 - 100 mm

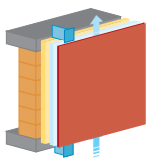
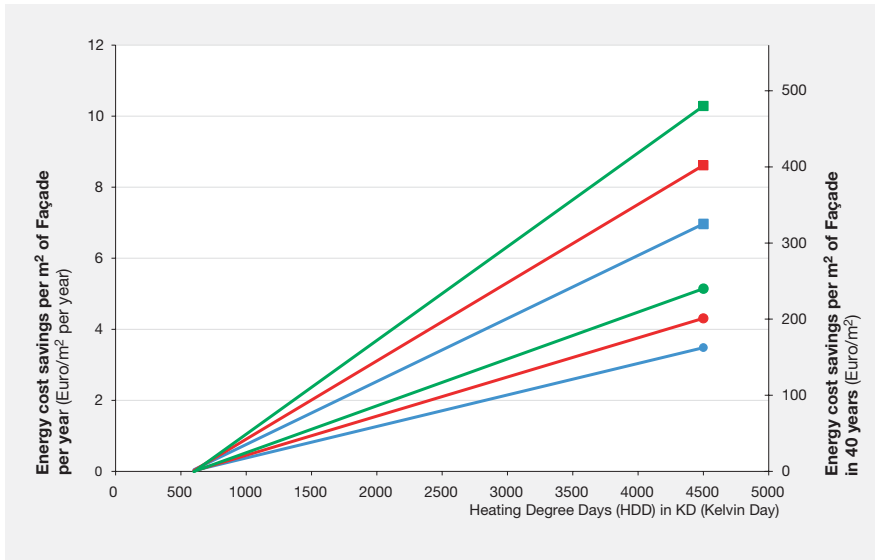

Sidney
Mexico
Shanghai
Bogota
Madrid
Beijing
Vancouver
Chicago
Warsaw
Stockholm

Masonry

In the case of masonry walls and wooden structures, energy cost savings thanks to façade insulation are somewhat lower. Since these construction types are slightly more efficient in the reference case without insulation, additional benefits are slightly lower as compared to concrete or steel studs. However, energy cost savings are still considerable also in these cases. For masonry, energy cost savings exceed 100 Euro/m² over a life span of 40 years in locations with HDD of about 2000 and more. Even 200 Euro/m² and more may be saved if an consumer energy price of 0.1 Euro/kWh is expected. Thus, energy cost savings allow for paying off at least a part of the costs of the ventilated façade. Hence, as a whole, insulated ventilated façades are an efficient and cost-effective system with many other additional benefits (see next pages).

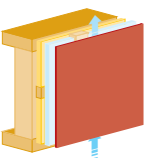
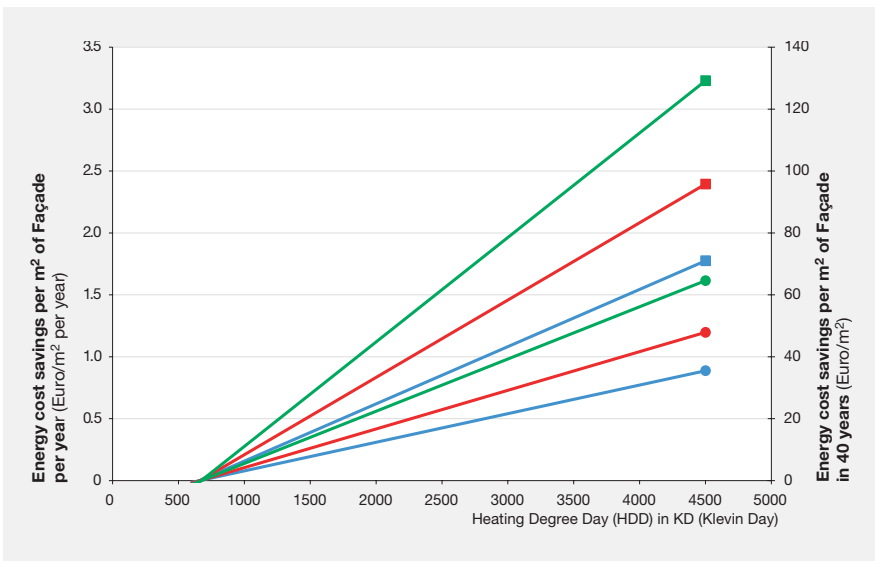

Sidney
Mexico
Shanghai
Bogota
Madrid
Beijing
Vancouver
Chicago
Warsaw
Stockholm

Wooden Structure

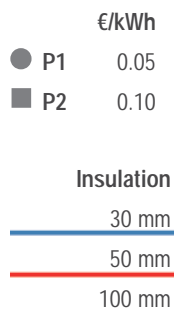

Life cycle costs

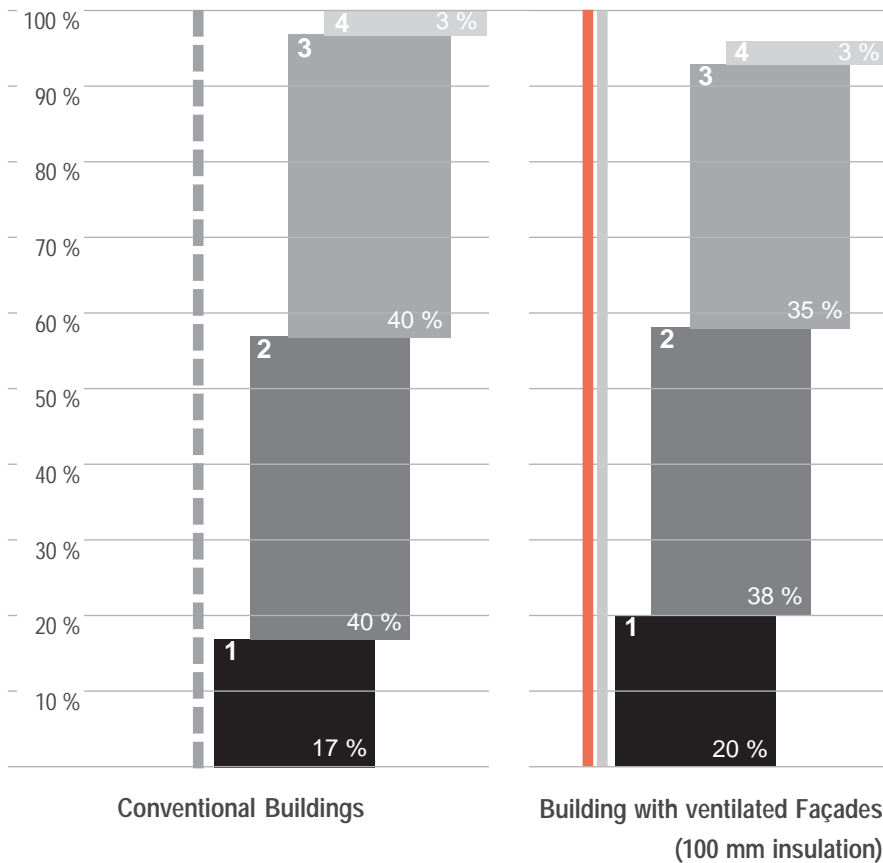

The costs of a building over its whole life expectancy can be sub-divided into four categories:

- 1** Design and construction
- 2** Operation
- 3** Maintenance / renewal
- 4** Deconstruction

The system as a whole

The SWISSPEARL ventilated façade is the most reliable system from the viewpoint of building physics. All its elements are designed for best balance to slow down the heat and cold transfer through the building envelope in both directions. Thanks to the high design versatility, the outer skin can be shaped with inclined parts to reduce the sun impact. It also allows the very aesthetic integration of sun-shading elements made of the same material.

SWISSPEARL ventilated façades have proved in severe climates to be very energy-smart and cost-effective over the long term and ensure a longer life expectancy for the building structure and the building envelope with low-cost maintenance. They therefore significantly help reduce the greenhouse gas emissions.

For construction information, see brochure „Designing with Swisspearl“ and Design and Installation Manual.

The share of each category depends on the type and function of building. It is also different for a new construction and a renovation, but operation and maintenance of the building over 40 years account for at least 70 % of the total bill.

Distribution of costs also varies with the building technology. The initial investment for energy-efficient buildings is higher than for a conventional construction, but this is more than compensated by the lower energy costs to cover annually with a high risk of growing expenses. Whereas erection costs are a defined and very small part of the whole costs, the expenses involved in the operating-energy needs of buildings are important and will keep growing in the future.

When high quality materials are used for the outer skin to ensure a long period of use without heavy maintenance expenses and with the appropriate insulation for the local climate, ventilated façades are more cost-efficient than traditionally designed buildings. Keeping in mind that in most of the countries, most of the structures realised in 1960 to 1990 do not meet green standards, energy-conscious façade renovation could save huge heating and/cooling costs, providing a quick return on investment for rehabilitation projects.

Perforated panels



Ljubljana, Slovenia



Hjärups, Sweden



Herisau, Switzerland

Perforated panels open up tremendous creative possibilities. Not only as decorative elements, but also to bring daylight into the buildings or diminish its brightness and glare in sun exposed areas. With reduced heat loads or losses.

Fully customizable, perforated Swisspearl panels may be used as fixed elements or as sliding shutters. Perforation shapes and patterns according to the architect's vision and inspiration allow exciting light transmission with the same monolithic material as used for the rest of the façade.



Meggen, Switzerland

This architectural solution for partly controlled light transmissivity can be realised with any product of the Swisspearl range, including with panels coated on both sides and different finishing. For further details, see the brochure „Designing with Swisspearl“

Benefits



A truly good way for new and existing buildings to incorporate energy efficiency and sustainability at controlled costs.



Syracuse (NY), USA

Acting for to-morrow

Building to-day is not just designing and realising a project meeting the defined function and budget of the client. Since the building will stand for a long time in the urban landscape and is prone to generating important CO₂ emissions during its whole life cycle, architect, builder and owner have also to take into account the long-term evolution in the social structures and ecological needs of the generations to come. Energy responsible construction and refurbishment is the right approach.

In future, the latent and selling value of a building will always more be partly determined by

- Its ecological performance, i.e. its capability to reduce significantly the embodied and the operating energy.
- Its ability to offer sound living and working conditions over a long period of use (social value) without heavy costs to regenerate the physical and aesthetical comfort.

Any measure to reduce the adverse effects of the increased CO₂ emissions has additional benefits for a wide range of systems. This is true also for the built environment, although owners and investors tend to underestimate these additional financially positive consequences of improved energy efficiency and sound building envelope. For themselves, for the occupants and for the society.



Bloomingdale (IL), USA

Mens sana...

Generally speaking, high performance buildings are meeting and connecting places. They will have to satisfy even more and higher requirements of intensive use. Not only regarding their functionality, but also regarding their living quality as tangible benefit to the occupants. Sound building materials and atmosphere (green materials, low emissions, interior climate including thermal comfort, etc.) but also aesthetic appearance fostering encounter and communication (attractive appeal deriving from the building image), as well as other factors having a positive influence on activities and feeling of well-being of users in a sound environment.

In particular, in the high-end market segment, the relevance of these aspects will continue to increase and become a major factor for the decision makers, since they correspond to important financial savings or gains.

The innovative SWISSPEARL façade systems with advanced technology combining the energy-efficiency of insulation and air circulation are energy performing and cost saving while they ensure a longer, sound life of the building structure. Furthermore, the proven durability of the cement composite panels over four to five decades, virtually without any maintenance, contributes to the wellness and efficiency of the users of any kind of building. Last but not least, the very attractive appearance of the façades will remain nearly unchanged for a very long time, thus respecting the architect's aesthetical design and the owner's image intention.



Salem (OR), USA



Nykøping, Denmark



Seoul, South Korea



Zagreb, Croatia

...in corpore sano

The influence of the indoor environmental quality on health and productivity of the building users and its economic consequences are widely underestimated. In developed countries, most people spend roughly 20 hours a day in closed rooms. Many studies evidence that a sound interior climate thanks to energy efficiency measures corresponds to enormous savings in health costs and formidable gains in productivity.

A sound interior climate is an environment with natural lighting, sufficient ventilation, 40 to 60 % relative humidity and controlled temperature, without pollutants, allergens, mould, and other sick building issues. Doctors and experts think that - without appropriate measures - respiratory problems, allergies, asthma, etc. will continue to increase with exploding costs for the individual and the society.

Improving the indoor climate means not only reducing these direct health expenses. Linked

to these illnesses are the costs due to the lower working performance of people affected by the environmental discomfort and the productivity losses resulting from the increased absenteeism in all sectors.

The annual bill reaches billions and billions in the industrial nations. Therefore, building energy efficient measures resulting also, for instance, in 25 % less lost working days and in a 25 % improvement of lower productivity are an investment with many pay back components for office and commercial buildings, administration, public buildings, etc.

The principle of the SWISSPEARL ventilated façade significantly improves the indoor environmental quality because the breathing walls and the air circulation evacuate most of the indoor humidity that lead to mould and many health problems in conventional buildings. Therefore, SWISSPEARL façades contribute to better health and well-being of the building occupants.

Without insulation

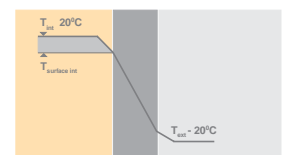

$T_{\text{surface int}}$

Temperature on inner surface lower than room temperature

Low comfort: great difference in temperature of surface and room.

With insulation

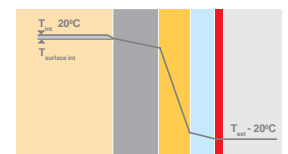

$T_{\text{surface int}}$

Temperature of inner surface more or less similar to room temperature

Higher comfort: very small difference in temperature of surface and room.

Humidity and Heat protection



Copenhagen, Denmark



Cantù, Italy



Malmö, Sweden



Stromstad, Sweden

Value and profitability

Every building project requires a deep need and profitability analysis, computed over the whole period of use. In such a global approach, the lowest figure is in the long run definitely not the cheapest investment. Façades have constantly to withstand various weather stresses while protecting their occupants and providing living comfort. With high quality material for the envelope, the weather skin has a much longer life expectancy with an attractive look for decades. Maintaining the value of the initial investment without expensive maintenance later on are financial benefits that add to the savings achieved year after year thanks to the energy efficiency of the building. With lower CO₂ emissions per year.

SWISSPEARL ventilated façades meet all these requirements. They are intended for cost and environment conscious building owners and architects who wish energy-performing, high-profile buildings with reliable long time quality. When designed and realised by good architects and builders according to high standards, SWISSPEARL ventilated façades will globally cost little less to build and operate than conventional façades designed according to traditional methods. With a finally higher ROI. A major asset for the investor.

Green is beautiful

Energy efficiency of new and existing buildings needs the mastery of the corresponding technologies. This is not at all detrimental to the architect's creative freedom. On the contrary, SWISSPEARL façade systems and their nearly unlimited designing possibilities allow cutting edge contemporary architecture for green buildings with a unique and noble expression. Pages 19 to 22 show a few examples of such intelligent creativity.

For further examples of attractive architecture, see brochure „Designing with Swisspearl“.



Ljubljana, Slovenia



In comparison to man's life, the change in climate is a long-term process that cannot be reversed rapidly. But the right balance of human needs and energy conservation measures should allow to control its extent.

For the sake of the planet and the next generations.

Protect the environment, save energy resources with SWISSPEARL

SWISSPEARL system provides the key to energy conserving solutions with

- A long-term good return on capital for building owners and investors.
- Much lower energy costs.
- Higher comfort and habitable quality for the users.
- Long lasting beauty of high quality architecture.



NOAA Suitland (MD), USA

Units

- toe** tonne of oil equivalent, or 107 kilocalories, or 41.86 GJ (Gigajoule)
- Mtoe** million toe
- GW** Gigawatt or 10^9 watt
- kWh** kilowatt-hour or 10^3 watt-hour
- MWh** megawatt-hour or 10^6 watt-hour
- TWh** Terawatt-hour or 10^{12} watt-hour
- t** metric tonnes, or 1000 kilogrammes
- Mt** Million metric tonnes

Impressum

Eternit (Switzerland) AG
 SWISSPEARL, CH 8867 Niederurnen, Switzerland
www.swisspearl-architecture.com
Dr. Martin Jakob
 TEP Energy GmbH, Zürich
www.tep-energy.ch
 With the co-operation of Centre of Energy Policy and Economy (CEPE) of ETH Zürich, Prof. Eberhard Jochem

Sources | Last access summer 08

- **ACEEE**
 American Council for an Energy-Efficient Economy | www.aceee.org
- **ECEEE**
 European Council for an Energy Efficient Economy | www.eceee.org
- **ECOFYS**
 Research and consultancy on renewable energy, energy savings and climate policies
www.ecofys.com
- **EPA**
 U.S. Environmental Protection Agency
www.epa.gov
- **EU-27 report**
 European Energy and Transport - Trends to 2030
 Office for Official Publications of the European Communities, 2008 Luxembourg | www.ec.europa.eu/dgs/energy_transport/publication/analysis_en.htm

- **IEA**
 International Energy Agency | www.iea.org
- **IPCC**
 Intergovernmental Panel on Climate Change, Climate Change 2007, Fourth Assessment Report | www.ipcc.ch
- **McKinsey & Company** | www.mckinsey.com
- **MRE**
 Munich Re Group, Topics Geo Natural Catastrophes 2007
- **NOAA/NCDC/NESDIS**
 National Oceanic and Atmospheric Administration | www.noaa.gov

**Ventilated Façades: Cost efficient contribution
to lower energy consumption
and CO₂ emissions**

SWISSPEARL®

Authorized Distributor

www.swisspearl-architecture.com

PREMIUM

SWISS QUALITY

FAÇADE SYSTEMS

FOR HIGH-END

ARCHITECTURE